

# 以心换新 力无止境

USE OUR HEARTS TO GAIN NEW IDEA, THRER WILL BE ENDLESS OF POWER

## 起重特性表

RATED LIFTING CAPACITY TABLE

单位(UNIT): kg

工作幅度 WORKING RADIUS(m)	主 臂 BOOM			主臂+副臂BOOM+JIB 21.7+6m
	支腿全伸、后方、侧方作业 REAR & SIDE WORKING AREA WITH OUTRIGGER FULLY EXTENDED			
	8.7m	15.2m	21.7m	
3.0	12000			
3.5	11000	7300		
4.0	10000	7300		
4.5	9200	7000		
5.0	7400	6500	4600	
5.5	6450	6200	4600	
6.0	5300	5500	4300	
6.5	4500	4760	4100	
7.0	4000	4200	3700	2000
7.5		3800	3500	1900
8.0		3350	3300	1830
8.5		3000	3100	1770
9.0		2750	2820	1710
9.5		2450	2600	1660
10.0		2260	2400	1610
11.0		2000	2050	1520
12.0		1620	1750	1440
13.0		1350	1500	1370
14.0			1350	1300
15.0			1150	1240
16.0			990	1110
17.0			750	990
18.0			650	870
19.0			550	780

说明:

- 以上作业工况均为支腿全伸, 不允许在不打支腿的情况下吊重。
- 表中粗线以上数值是由起重机的结构强度所决定的, 其余由起重机整机稳定性所决定的。
- 表中所列数值为最大允许值, 并包括吊钩重量(主吊钩重 140kg, 副吊钩重 40kg)。
- 表中所列数值是指吊重后吊钩中心至回转中心的水平距离, 当实际臂长和工作幅度在两数值之间时, 应按较大臂长和幅度确定起重量。

Note:

- Above working condition is with outrigger fully extended.
- Capacities above the thick line in the table are based on construction strength of crane, the others, on stability of the complete machine.
- Capacities listed in the table are all max. permissible value and include weight of hook (main hook, 140kg, mauxiliary hook, 40kg)
- The values listed in the table is a horizontal distance from centerline of hook to centerline of clewing. When actual boom length and working radius are between two values, should determine capacity according to bigger boom length and radius.

### 中联重科浦沅分公司

地址: 湖南省长沙市芙蓉中路三段 613 号  
电话: 0731-5667210  
传真: 0731-5582657  
邮编: 410007  
网址: www.puyuan.com.cn

PUYUAN SUB-COMPANY OF ZOOMLION HOLDING GROUP

ADD: NO.613 THE 3TH DISTRICT FURONG MIDDLE ROAD, CHANGSHA, HUNAN  
TEL: 0731-5667210  
FAX: 0731-5582657  
PC: 410007  
HTTP://WWW.PUYUAN.COM.CN

### 营销部

销售热线: 0731-5667230 5311766  
服务热线: 0731-5667004  
备件服务热线: 8008786119 0731-5667276  
传真: 0731-5585850  
E-mail: sales@puyuan.com.cn

SALES DEPARTMENT

TEL: 0731-5667230 5311766  
SERVICE TEL: 0731-5667004  
SPARE PARTS SALE: 8008786119 0731-5667276  
FAX: 0731-5585850  
E-mail: sales@puyuan.com.cn

### 浦沅进出口公司

总部电话: 0731-5667238  
传真: 0731-5591796  
E-mail: pyiec@public.cs.hn.cn

CHANGSHA PUYUAN IMP. & EXP. CO., LTD.

HEAD OFFICE: 0731-5667238  
FAX: 0731-5591796  
E-mail: export@puyuan.com.cn

2008年1月版

# PUYUAN

## ■ 全液压汽车起重机

Full Hydraulic Truck Crane

## ■ QY12H



**浦沅**

注意: 样本所載的圖片和技術參數, 由於設計上改進等原因, 有可能與用戶交貨產品不符, 請予理解, 恕不另行通知。  
NOTICE: PICTURES AND TECHNICAL DATA SUBJECT TO CHANGE WITHOUT NOTICE FOR IMPROVEMENT.

## QY12H



### 主要特点 MAIN FEATURES

浦沅牌 QY12H (ZLJ5151JQZ12H) 型汽车起重机是全回转伸缩臂式全液压汽车起重机, 最大额定起重量 12 吨。

PUYUAN QY12H(ZLJ5151JQZ12H) truck crane is a type of hydraulic truck crane with full-slewing telescoping boom .It has max-lifting capacity of 12t.

采用全驾驶室 (三人) 自制专用底盘, 配玉柴 YC4G180-20 增压中冷环保发动机 (欧 I 或欧 II), 采用液压助力转向, 配整体式方向机, 视野宽阔, 驶乘、操作轻便、舒适。底盘主要配套件采用东风系列产品, 质量可靠, 维修方便。

It adopts full-width self-made special purpose chassis (three persons), Yuchai YC4G180-20 supercharged middle-cool environment friendly engine (Europe?), hydraulic booster steering, whole steering wheel, thus make wide vision, convenient and comfortable operation ,Chassis accessory mainly adopts Dong Feng series products that is with reliable quality and convenient for service .

采用现代流线型的全驾驶室和操纵室, 驾驶室内覆盖内饰, 配豪华工作仪表台, 液压减震座椅、空调、暖风装置等, 上下方便, 实现人机完美结合。

The full mounted driver's cad and the operator's are streamline style. The driver's cad is equipped with soft decoration materials, luxury gauge, hydraulic shock-absorbing seats, air-conditioner and heater to provide the driver a comfortable environment and realize man and machine intergration.

全覆盖走台板, 外形美观, 便于检测和维修。配上车启动、熄火装置。

The covered deck with elegant appearance makes checking and maintainance convenient. It is filled with superstructure starting device and extinction device .

除液压系统装有全套安全装置外, 并装有高度限位器、称重、负荷、角度指示器等多种安全装置及齐全的照明, 以确保操作安全可靠, 便于夜间作业。

The hydraulic system is also equipped with the safety devices such as height limiter, weight indicator, moment limiter, angle indicator and all kinds of illuminator besides all sets of safety devices ,which ensures the safety and reliable operation and is convenient for night work.

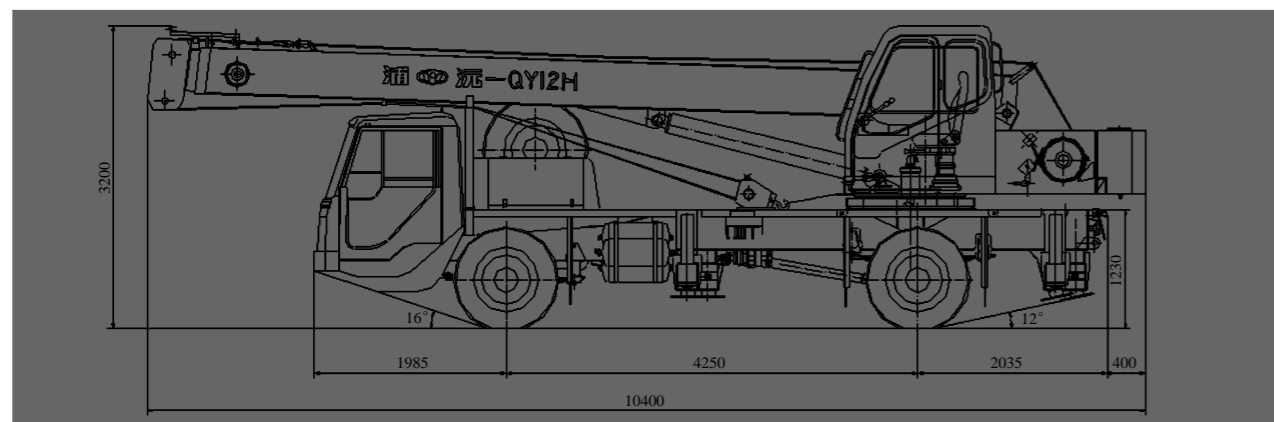

外形尺寸图 OVERALL DIMENSIONS

### 主要技术参数

### Main technical specifications

项 目 (ITEM)	单 位 (UNIT)	数 值 (DATA)		
工作性能参数 WORKING PERFORMANCE SPECIFICATIONS	最大额定总起重量	MAX. RATED LIFTING CAPACITY	kg	12000
	基本臂最大起重力矩	MAX. LIFTING MOMENT WITH MIN. BOOM LENGTH	kN.m	414
	最长主臂最大起重力矩	MAX. LIFTING MOMENT WITH MAX. BOOM LENGTH	kN.m	266.5
	主臂最大起升高度	BOOM MAX. LIFTING HEIGHT	m	22.3
	副臂最大起升高度	JIB MAX. LIFTING HEIGHT	m	27.5
工作速度 WORKING SPEED	单绳最大速度	SINGLE LINE MAX. SPEED	m/min	90
	起重臂伸出时间	LIFTING BOOM EXTENDING TIME	s	52
	起重臂起臂时间	LIFTING BOOM ELEVATING TIME	s	40
	回转速度	SLEWING SPEED	r/min	0-3
行驶参数 TRAVELLING SPECIFICATIONS	最高行驶速度	MAX. TRAVELLING SPEED	km/h	78
	最大爬坡度	MAX. GRADEABILITY	%	30
	最小转弯半径	MIN. TURNING RADIUS	m	8.5
	最小离地间隙	MIN. CLEARANCE	m	0.26
	接近角	APPROACH ANGLE	°	16
	离去角	ANGLE OF DEPARTURE	°	12
	自由加速烟度排放限值 百公里油耗	ACCELERATE FREELY DUST DISPLACEMENT OIL CONSUMPTION PER. 100 KILOMETERS	符合 GB3847-1999	GB17691-2001 的规定
质量参数 MASS SPECIFICATIONS	行驶状态自重 (总质量)	SELF-WEIGHT IN TRAVELLING CONDITION	kg	14780
	前轴轴荷	FRONT AXLE LOAD	kg	5360
	后轴轴荷	REAR AXLE LOAD	kg	9420
尺寸参数 DIMENSION SPECIFICATIONS	外形尺寸 (长×宽×高)	OVERALL DIMENSIONS (L×W×H)	mm	10400×2500×3200
	支腿纵向跨距	OUTRIGGER LONGITUDINAL SPAN	m	3.875
	支腿横向跨距	OUTRIGGER TRANSVERSAL SPAN	m	4.6
	主臂长	BOOM LENGTH	m	8.7-21.7
	主臂仰角	BOOM ANGLE	°	-3-75
	副臂长	JIB LENGTH	m	6
底 盘 CHASSIS	型号	TYPE		PY5170
	发动机型号	ENGINE MODEL		玉柴 YC4G180-20
	发动机功率	MAX. POWER OF ENGINE	kW/rpm	132/2300
	最大扭矩	MAX. TORQUE OF ENGINE	N.m/rpm	660/1300-1500

### 起升高度曲线图

#### LIFTING HEIGHT CURVE DIAGRAM

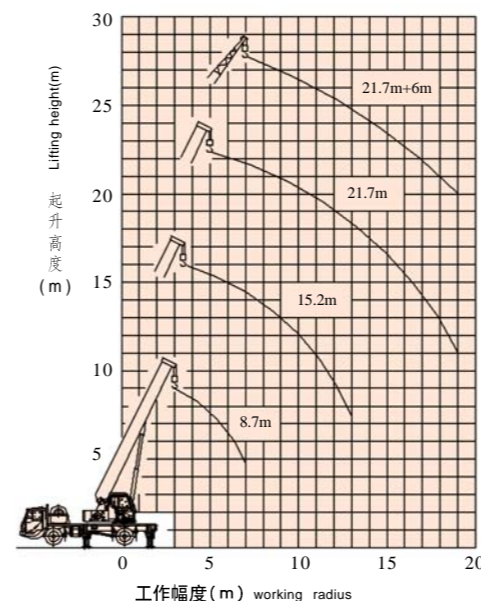

### 钢丝绳倍率

#### WIRE ROPE FALL

臂长 BOOM LENGTH (m)	8.7-15.2	15.2-21.7	21.7+6
倍率 FALLS	6	4	1

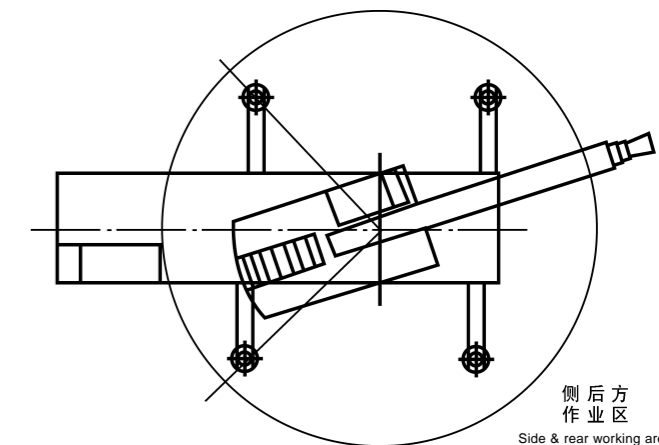

起重作业方位图  
WORKING AREA DIAGRAM