

ZLJ5420THB125-47

混凝土泵车

Truck-Mounted Concrete Pump

主要技术参数 Technical data

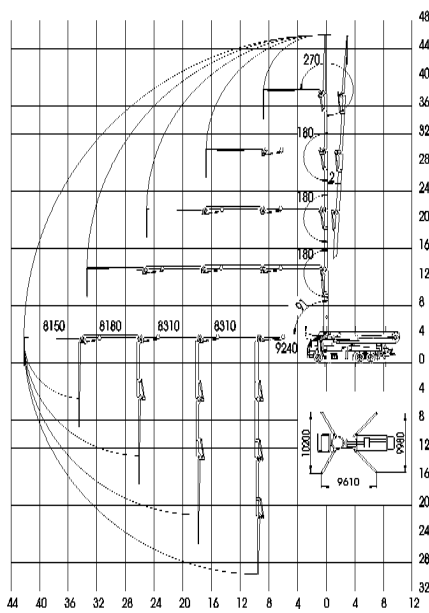

工作范围 Working range

最大理论输送量 Max theor concrete output	(m ³ /h)	129
最大理论出口压力 Max concrete pressure	(MPa)	12
料斗容积 Hopper volume	(L)	650
上料高度 Filling height on support	(mm)	1540
分配阀形式 Type of distributing valve		S 管阀 S valve
垂直布料高度 Vertical reach	(m)	46.2
水平布料半径 Horizontal reach from center of slewing column	(m)	42.3
布料深度 Depth reach	(m)	33.2
回转角度 Slewing range	(°)	365
输送管直径 Dia. of concrete delivery pipeline	(mm)	125
臂架节数 Number of articulated points		5
各节臂旋转角度 Folding angles of each section	(°)	91/180/180/180/270
端部软管长度 Length of end hose	(m)	4
底盘型号 Model of chassis	VOLVO	FM12
驱动型式 Driven type		8 × 4
轴距 Wheel base	(mm)	1793+4407+1370
轮距 (F/R) Tread(Front/Rear)	(mm)	2028/1835 或 1872
柴油机功率及转速 Engine power and rotation speed	(kW/r/min)	279/1700~1800
柴油机扭矩及转速 Engine torque and r.p.m	(N · m/r/min)	1850/1050~1300
柴油机排放依据标准 Exhaust emission standard of engine		欧洲 III Eur. III
整车最高行驶速度 Max. running speed of vehicle	(km/h)	95
整车最小转弯直径 Min turning dia.	(m)	≤ 22
整车质量 Total weight	(kg)	40600
外形尺寸 (长×宽×高) Overall dimension (length × width × Height)	(mm)	11980 × 2500 × 3980

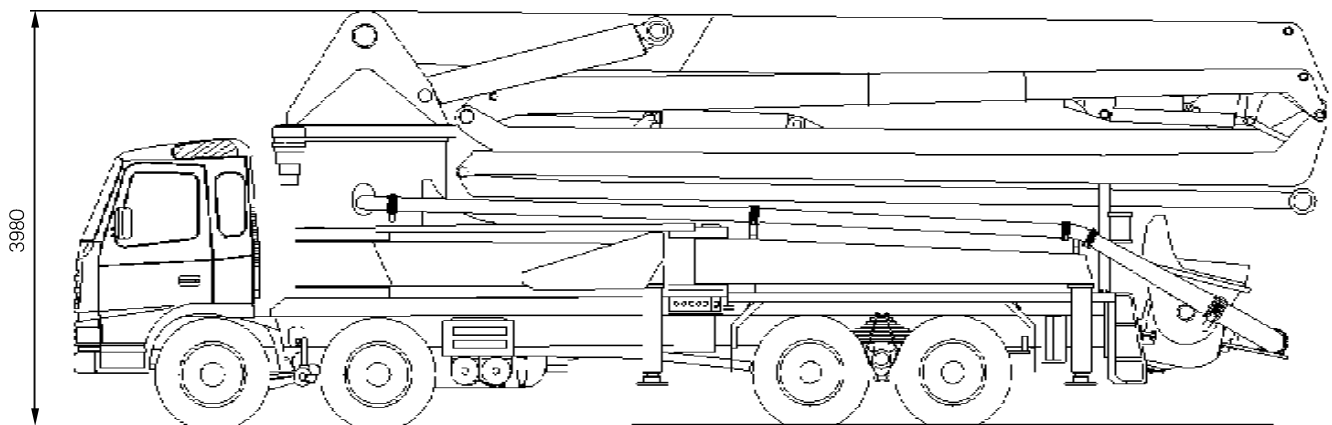

11980(宽 2500)

外形尺寸 Overall dimension